

Unit 3

More Songs with "B" "A" and "G"

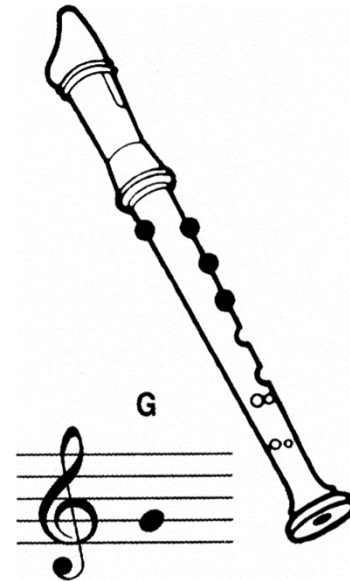
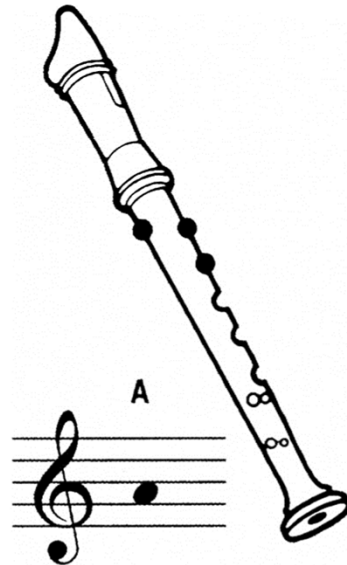
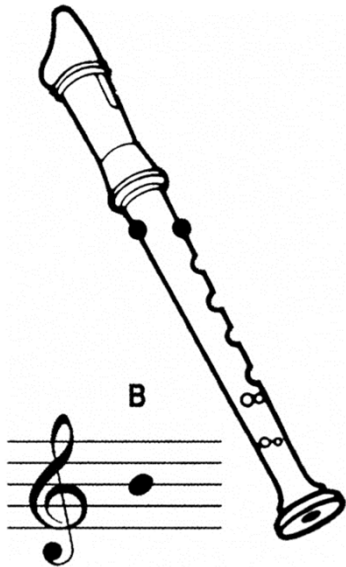

Reminder Tips

- Left Hand on Top
- Cover Holes Completely
- Blow Gently
- Think “duh”



Review of Notes

 = Half Note = 2 beats

 = Dotted Half Note = 3 beats

And..



= Quarter Note = 1 beat (Say "ta")



= Two Eighth Notes = 1 beat (Say "ti ti")



= One Eighth Note = $\frac{1}{2}$ beat



= Quarter Rest = 1 silent beat (Think Rest)

Something Hiding

1. Be prepared to play “B” “A” “G”.
2. At the end of the song, a volunteer will choose an object from a bag and create a story about the object.
3. On teacher's triangle cue, stop talking.
4. Repeat song several times, asking for a new volunteer.

Practice Tips

- First Time: Speak the rhythm.
Example “ta ta”.
- Second Time: Sing the letter name while covering the correct holes for the pitch.
- Third Time: Play the song.

Where are the changes in *Hot Cross Buns* Variation 1?

Hot Cross Buns (Variation 1)



Hot cross gold-en buns. Hot cross gold-en buns. One a penny two a penny. Hot cross gold-en buns



Where are the changes in *Hot Cross Buns* Variation 2?

Hot Cross Buns (Variation 2)



One a pen-ny two a pen-ny. Hot cross buns.

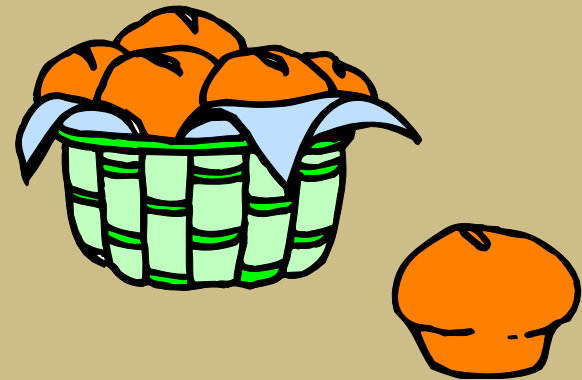

Hot Cross Buns Extension

1. Create words for Variation 2.
2. Add a bass accompaniment.



G D' D' G D'

3. Add unpitched percussion such as a tambourine, drum, woodblock.
4. Create a new variation with a friend and be prepared to share with class.

Strolling

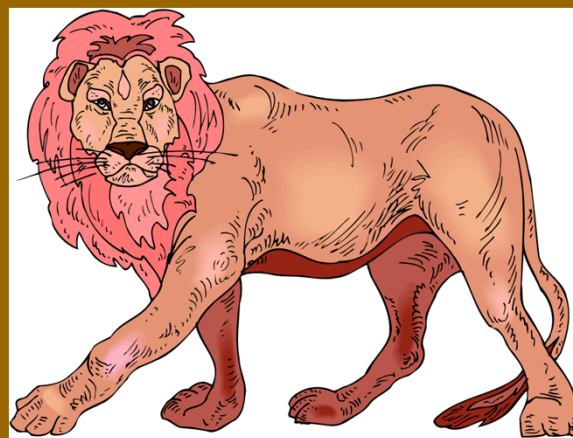

Try Three

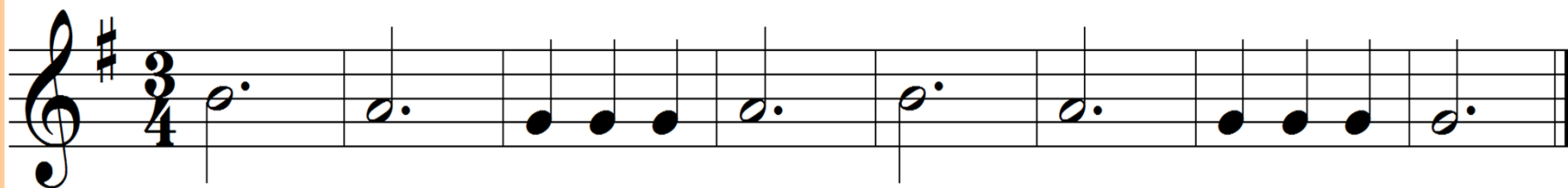

Upward

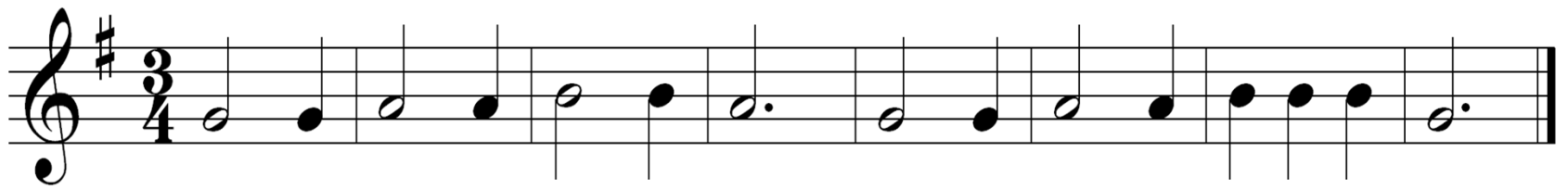

Strolling Try Three Upward



A musical score consisting of three staves, each in treble clef with a key signature of one sharp (F#) and a time signature of 3/4. The first staff begins with a treble clef, a sharp sign, and a 3/4 time signature. The notes are: G4, A4, B4, C5, D5, E5, F#5, G5, A5, B5, C6, D6, E6, F#6, G6, A6, B6, C7, D7, E7, F#7, G7, A7, B7, C8, D8, E8, F#8, G8, A8, B8, C9, D9, E9, F#9, G9, A9, B9, C10, D10, E10, F#10, G10, A10, B10, C11, D11, E11, F#11, G11, A11, B11, C12, D12, E12, F#12, G12, A12, B12, C13, D13, E13, F#13, G13, A13, B13, C14, D14, E14, F#14, G14, A14, B14, C15, D15, E15, F#15, G15, A15, B15, C16, D16, E16, F#16, G16, A16, B16, C17, D17, E17, F#17, G17, A17, B17, C18, D18, E18, F#18, G18, A18, B18, C19, D19, E19, F#19, G19, A19, B19, C20, D20, E20, F#20, G20, A20, B20, C21, D21, E21, F#21, G21, A21, B21, C22, D22, E22, F#22, G22, A22, B22, C23, D23, E23, F#23, G23, A23, B23, C24, D24, E24, F#24, G24, A24, B24, C25, D25, E25, F#25, G25, A25, B25, C26, D26, E26, F#26, G26, A26, B26, C27, D27, E27, F#27, G27, A27, B27, C28, D28, E28, F#28, G28, A28, B28, C29, D29, E29, F#29, G29, A29, B29, C30, D30, E30, F#30, G30, A30, B30, C31, D31, E31, F#31, G31, A31, B31, C32, D32, E32, F#32, G32, A32, B32, C33, D33, E33, F#33, G33, A33, B33, C34, D34, E34, F#34, G34, A34, B34, C35, D35, E35, F#35, G35, A35, B35, C36, D36, E36, F#36, G36, A36, B36, C37, D37, E37, F#37, G37, A37, B37, C38, D38, E38, F#38, G38, A38, B38, C39, D39, E39, F#39, G39, A39, B39, C40, D40, E40, F#40, G40, A40, B40, C41, D41, E41, F#41, G41, A41, B41, C42, D42, E42, F#42, G42, A42, B42, C43, D43, E43, F#43, G43, A43, B43, C44, D44, E44, F#44, G44, A44, B44, C45, D45, E45, F#45, G45, A45, B45, C46, D46, E46, F#46, G46, A46, B46, C47, D47, E47, F#47, G47, A47, B47, C48, D48, E48, F#48, G48, A48, B48, C49, D49, E49, F#49, G49, A49, B49, C50, D50, E50, F#50, G50, A50, B50, C51, D51, E51, F#51, G51, A51, B51, C52, D52, E52, F#52, G52, A52, B52, C53, D53, E53, F#53, G53, A53, B53, C54, D54, E54, F#54, G54, A54, B54, C55, D55, E55, F#55, G55, A55, B55, C56, D56, E56, F#56, G56, A56, B56, C57, D57, E57, F#57, G57, A57, B57, C58, D58, E58, F#58, G58, A58, B58, C59, D59, E59, F#59, G59, A59, B59, C60, D60, E60, F#60, G60, A60, B60, C61, D61, E61, F#61, G61, A61, B61, C62, D62, E62, F#62, G62, A62, B62, C63, D63, E63, F#63, G63, A63, B63, C64, D64, E64, F#64, G64, A64, B64, C65, D65, E65, F#65, G65, A65, B65, C66, D66, E66, F#66, G66, A66, B66, C67, D67, E67, F#67, G67, A67, B67, C68, D68, E68, F#68, G68, A68, B68, C69, D69, E69, F#69, G69, A69, B69, C70, D70, E70, F#70, G70, A70, B70, C71, D71, E71, F#71, G71, A71, B71, C72, D72, E72, F#72, G72, A72, B72, C73, D73, E73, F#73, G73, A73, B73, C74, D74, E74, F#74, G74, A74, B74, C75, D75, E75, F#75, G75, A75, B75, C76, D76, E76, F#76, G76, A76, B76, C77, D77, E77, F#77, G77, A77, B77, C78, D78, E78, F#78, G78, A78, B78, C79, D79, E79, F#79, G79, A79, B79, C80, D80, E80, F#80, G80, A80, B80, C81, D81, E81, F#81, G81, A81, B81, C82, D82, E82, F#82, G82, A82, B82, C83, D83, E83, F#83, G83, A83, B83, C84, D84, E84, F#84, G84, A84, B84, C85, D85, E85, F#85, G85, A85, B85, C86, D86, E86, F#86, G86, A86, B86, C87, D87, E87, F#87, G87, A87, B87, C88, D88, E88, F#88, G88, A88, B88, C89, D89, E89, F#89, G89, A89, B89, C90, D90, E90, F#90, G90, A90, B90, C91, D91, E91, F#91, G91, A91, B91, C92, D92, E92, F#92, G92, A92, B92, C93, D93, E93, F#93, G93, A93, B93, C94, D94, E94, F#94, G94, A94, B94, C95, D95, E95, F#95, G95, A95, B95, C96, D96, E96, F#96, G96, A96, B96, C97, D97, E97, F#97, G97, A97, B97, C98, D98, E98, F#98, G98, A98, B98, C99, D99, E99, F#99, G99, A99, B99, C100, D100, E100, F#100, G100, A100, B100, C101, D101, E101, F#101, G101, A101, B101, C102, D102, E102, F#102, G102, A102, B102, C103, D103, E103, F#103, G103, A103, B103, C104, D104, E104, F#104, G104, A104, B104, C105, D105, E105, F#105, G105, A105, B105, C106, D106, E106, F#106, G106, A106, B106, C107, D107, E107, F#107, G107, A107, B107, C108, D108, E108, F#108, G108, A108, B108, C109, D109, E109, F#109, G109, A109, B109, C110, D110, E110, F#110, G110, A110, B110, C111, D111, E111, F#111, G111, A111, B111, C112, D112, E112, F#112, G112, A112, B112, C113, D113, E113, F#113, G113, A113, B113, C114, D114, E114, F#114, G114, A114, B114, C115, D115, E115, F#115, G115, A115, B115, C116, D116, E116, F#116, G116, A116, B116, C117, D117, E117, F#117, G117, A117, B117, C118, D118, E118, F#118, G118, A118, B118, C119, D119, E119, F#119, G119, A119, B119, C120, D120, E120, F#120, G120, A120, B120, C121, D121, E121, F#121, G121, A121, B121, C122, D122, E122, F#122, G122, A122, B122, C123, D123, E123, F#123, G123, A123, B123, C124, D124, E124, F#124, G124, A124, B124, C125, D125, E125, F#125, G125, A125, B125, C126, D126, E126, F#126, G126, A126, B126, C127, D127, E127, F#127, G127, A127, B127, C128, D128, E128, F#128, G128, A128, B128, C129, D129, E129, F#129, G129, A129, B129, C130, D130, E130, F#130, G130, A130, B130, C131, D131, E131, F#131, G131, A131, B131, C132, D132, E132, F#132, G132, A132, B132, C133, D133, E133, F#133, G133, A133, B133, C134, D134, E134, F#134, G134, A134, B134, C135, D135, E135, F#135, G135, A135, B135, C136, D136, E136, F#136, G136, A136, B136, C137, D137, E137, F#137, G137, A137, B137, C138, D138, E138, F#138, G138, A138, B138, C139, D139, E139, F#139, G139, A139, B139, C140, D140, E140, F#140, G140, A140, B140, C141, D141, E141, F#141, G141, A141, B141, C142, D142, E142, F#142, G142, A142, B142, C143, D143, E143, F#143, G143, A143, B143, C144, D144, E144, F#144, G144, A144, B144, C145, D145, E145, F#145, G145, A145, B145, C146, D146, E146, F#146, G146, A146, B146, C147, D147, E147, F#147, G147, A147, B147, C148, D148, E148, F#148, G148, A148, B148, C149, D149, E149, F#149, G149, A149, B149, C150, D150, E150, F#150, G150, A150, B150, C151, D151, E151, F#151, G151, A151, B151, C152, D152, E152, F#152, G152, A152, B152, C153, D153, E153, F#153, G153, A153, B153, C154, D154, E154, F#154, G154, A154, B154, C155, D155, E155, F#155, G155, A155, B155, C156, D156, E156, F#156, G156, A156, B156, C157, D157, E157, F#157, G157, A157, B157, C158, D158, E158, F#158, G158, A158, B158, C159, D159, E159, F#159, G159, A159, B159, C160, D160, E160, F#160, G160, A160, B160, C161, D161, E161, F#161, G161, A161, B161, C162, D162, E162, F#162, G162, A162, B162, C163, D163, E163, F#163, G163, A163, B163, C164, D164, E164, F#164, G164, A164, B164, C165, D165, E165, F#165, G165, A165, B165, C166, D166, E166, F#166, G166, A166, B166, C167, D167, E167, F#167, G167, A167, B167, C168, D168, E168, F#168, G168, A168, B168, C169, D169, E169, F#169, G169, A169, B169, C170, D170, E170, F#170, G170, A170, B170, C171, D171, E171, F#171, G171, A171, B171, C172, D172, E172, F#172, G172, A172, B172, C173, D173, E173, F#173, G173, A173, B173, C174, D174, E174, F#174, G174, A174, B174, C175, D175, E175, F#175, G175, A175, B175, C176, D176, E176, F#176, G176, A176, B176, C177, D177, E177, F#177, G177, A177, B177, C178, D178, E178, F#178, G178, A178, B178, C179, D179, E179, F#179, G179, A179, B179, C180, D180, E180, F#180, G180, A180, B180, C181, D181, E181, F#181, G181, A181, B181, C182, D182, E182, F#182, G182, A182, B182, C183, D183, E183, F#183, G183, A183, B183, C184, D184, E184, F#184, G184, A184, B184, C185, D185, E185, F#185, G185, A185, B185, C186, D186, E186, F#186, G186, A186, B186, C187, D187, E187, F#187, G187, A187, B187, C188, D188, E188, F#188, G188, A188, B188, C189, D189, E189, F#189, G189, A189, B189, C190, D190, E190, F#190, G190, A190, B190, C191, D191, E191, F#191, G191, A191, B191, C192, D192, E192, F#192, G192, A192, B192, C193, D193, E193, F#193, G193, A193, B193, C194, D194, E194, F#194, G194, A194, B194, C195, D195, E195, F#195, G195, A195, B195, C196, D196, E196, F#196, G196, A196, B196, C197, D197, E197, F#197, G197, A197, B197, C198, D198, E198, F#198, G198, A198, B198, C199, D199, E199, F#199, G199, A199, B199, C200, D200, E200, F#200, G200, A200, B200, C201, D201, E201, F#201, G201, A201, B201, C202, D202, E202, F#202, G202, A202, B202, C203, D203, E203, F#203, G203, A203, B203, C204, D204, E204, F#204, G204, A204, B204, C205, D205, E205, F#205, G205, A205, B205, C206, D206, E206, F#206, G206, A206, B206, C207, D207, E207, F#207, G207, A207, B207, C208, D208, E208, F#208, G208, A208, B208, C209, D209, E209, F#209, G209, A209, B209, C210, D210, E210, F#210, G210, A210, B210, C211, D211, E211, F#211, G211, A211, B211, C212, D212, E212, F#212, G212, A212, B212, C213, D213, E213, F#213, G213, A213, B213, C214, D214, E214, F#214, G214, A214, B214, C215, D215, E215, F#215, G215, A215, B215, C216, D216, E216, F#216, G216, A216, B216, C217, D217, E217, F#217, G217, A217, B217, C218, D218, E218, F#218, G218, A218, B218, C219, D219, E219, F#219, G219, A219, B219, C220, D220, E220, F#220, G220, A220, B220, C221, D221, E221, F#221, G221, A221, B221, C222, D222, E222, F#222, G222, A222, B222, C223, D223, E223, F#223, G223, A223, B223, C224, D224, E224, F#224, G224, A224, B224, C225, D225, E225, F#225, G225, A225, B225, C226, D226, E226, F#226, G226, A226, B226, C227, D227, E227, F#227, G227, A227, B227, C228, D228, E228, F#228, G228, A228, B228, C229, D229, E229, F#229, G229, A229, B229, C230, D230, E230, F#230, G230, A230, B230, C231, D231, E231, F#231, G231, A231, B231, C232, D232, E232, F#232, G232, A232, B232, C233, D233, E233, F#233, G233, A233, B233, C234, D234, E234, F#234, G234, A234, B234, C235, D235, E235, F#235, G235, A235, B235, C236, D236, E236, F#236, G236, A236, B236, C237, D237, E237, F#237, G237, A237, B237, C238, D238, E238, F#238, G238, A238, B238, C239, D239, E239, F#239, G239, A239, B239, C240, D240, E240, F#240, G240, A240, B240, C241, D241, E241, F#241, G241, A241, B241, C242, D242, E242, F#242, G242, A242, B242, C243, D243, E243, F#243, G243, A243, B243, C244, D244, E244, F#244, G244, A244, B244, C245, D245, E245, F#245, G245, A245, B245, C246, D246, E246, F#246, G246, A246, B246, C247, D247, E247, F#247, G247, A247, B247, C248, D248, E248, F#248, G248, A248, B248, C249, D249, E249, F#249, G249, A249, B249, C250, D250, E250, F#250, G250, A250, B250, C251, D251, E251, F#251, G251, A251, B251, C252, D252, E252, F#252, G252, A252, B252, C253, D253, E253, F#253, G253, A253, B253, C254, D254, E254, F#254, G254, A254, B254, C255, D255, E255, F#255, G255, A255, B255, C256, D256, E256, F#256, G256, A256, B256, C257, D257, E257, F#257, G257, A257, B257, C258, D258, E258, F#258, G258, A258, B258, C259, D259, E259, F#259, G259, A259, B259, C260, D260, E260, F#260, G260, A260, B260, C261, D261, E261, F#261, G261, A261, B261, C262, D262, E262, F#262, G262, A262, B262, C263, D263, E263, F#263, G263, A263, B263, C264, D264, E264, F#264, G264, A264, B264, C265, D265, E265, F#265, G265, A265, B265, C266, D266, E266, F#266, G266, A266, B266, C267, D267, E267, F#267, G267, A267, B267, C268, D268, E268, F#268, G268, A268, B268, C269, D269, E269, F#269, G269, A269, B269, C270, D270, E270, F#270, G270, A270, B270, C271, D271, E271, F#271, G271, A271, B271, C272, D272, E272, F#272, G272, A272, B272, C273, D273, E273, F#273, G273, A273, B273, C274, D274, E274, F#274, G274, A274, B274, C275, D275, E275, F#275, G275, A275, B275, C276, D276, E276, F#276, G276, A276, B276, C277, D277, E277, F#277, G277, A277, B277, C278, D278, E278, F#278, G278, A278, B278, C279, D279, E279, F#279, G279, A279, B279, C280, D280, E280, F#280, G280, A280, B280, C281, D281, E281, F#281, G281, A281, B281, C282, D282, E282, F#282, G282, A282, B282, C283, D283, E283, F#283, G283, A283, B283, C284, D284, E284, F#284, G284, A284, B284, C285, D285, E285, F#285, G285, A285, B285, C286, D286, E286, F#286, G286, A286, B286, C287, D287, E287, F#287, G287, A287, B287, C288, D288, E288, F#288, G288, A288, B288, C289, D289, E289, F#289, G289, A289, B289, C290, D290, E290, F#290, G290, A290, B290, C291, D291, E291, F#291, G291, A291, B291, C292, D292, E292, F#292, G292, A292, B292, C293, D293, E293, F#293, G293, A293, B293, C294, D294, E294, F#294, G294, A294, B294, C295, D295, E295, F#295, G295, A295, B295, C296, D296, E296, F#296, G296, A296, B296, C297, D297, E297, F#297, G297, A297, B297, C298, D298, E298, F#298, G298, A298, B298, C299, D299, E299, F#299, G299, A299, B299, C300, D300, E300, F#300, G300, A300, B300, C301, D301, E301, F#301, G301, A301, B301, C302, D302, E302, F#302, G302, A302, B302, C303, D303, E303, F#303, G303, A303, B303, C304, D304, E304, F#304, G304, A304, B304, C305, D305, E305, F#305, G305, A305, B305, C306, D306, E306, F#306, G306, A306, B306, C307, D307, E307, F#307, G307, A307, B307, C308, D308, E308, F#308, G308, A308, B308, C309, D309, E309, F#309, G309, A309, B309, C310, D310, E310, F#310, G310, A310, B310, C311, D311, E311, F#311, G311, A311, B311, C312, D312, E312, F#312, G312, A312, B312, C313, D313, E313, F#313, G313, A313, B313, C314, D314, E314, F#314, G314, A314, B314, C315, D315, E315, F#315, G315, A315, B315, C316, D316, E316, F#316, G316, A316, B316, C317, D317, E317, F#317, G317, A317, B317, C318, D318, E318, F#318, G318, A318, B318, C319, D319, E319, F#319, G319, A319, B319, C320, D320, E320, F#320, G320, A320, B320, C321, D321, E321, F#321, G321, A321, B321, C322, D322, E322, F#322, G322, A322, B322, C323, D323, E323, F#323, G323, A323, B323, C324, D324, E324, F#324, G324, A324, B324, C325, D325, E325, F#325, G325, A325, B325, C326, D326, E326, F#326, G326, A326, B326, C327, D327, E327, F#327, G327, A327, B327, C328, D328, E328, F#328, G328, A328, B328, C329, D329, E329, F#329, G329, A329, B329, C330, D330, E330, F#330, G330, A330, B330, C331, D331, E331, F#331, G331, A331, B331, C332, D332, E332, F#332, G332, A332, B332, C333, D333, E333, F#333, G333, A333, B333, C334, D334, E334, F#334, G334, A334, B334, C335, D335, E335, F#335, G335, A335, B335, C336, D336, E336, F#336, G336, A336, B336, C337, D337, E337, F#337, G337, A337, B337, C338, D338, E338, F#338, G338, A338, B338, C339, D339, E339, F#339, G339, A339, B339, C340, D340, E340, F#340, G340, A340, B340, C341, D341, E341, F#341, G341, A341, B341, C342, D342, E342, F#342, G342, A342, B342, C343, D343, E343, F#343, G343, A343, B343, C344, D344, E344, F#344, G344, A344, B344, C345, D345, E345, F#345, G345, A345, B345, C346, D346, E346, F#346, G346, A346, B346, C347, D347, E347, F#347, G347, A347, B347, C348, D348, E348, F#348, G348, A348, B348, C349, D349, E349, F#349, G349, A349, B349, C350, D350, E350, F#350, G350, A350, B350, C351, D351, E351, F#351, G351, A351, B351, C352, D352, E352, F#352, G352, A352, B352, C353, D353, E353, F#353, G353, A353, B353, C354, D354, E354, F#354, G354, A354, B354, C355, D355, E355, F#355, G355, A355, B355, C356, D356, E356, F#356, G356, A356, B356, C357, D357, E357, F#357, G357, A357, B357, C358, D358, E358, F#358, G358, A358, B358, C359, D359, E359,

The capital letters above the song are **chords** which can be played on piano or guitar.

Au Clair de la Lune

The image shows a musical score for the song "Au Clair de la Lune". It consists of two staves of music in treble clef, with a key signature of one sharp (F#) and a time signature of 2/4. The melody is written with quarter and eighth notes. Above the notes, capital letters indicate the chords to be played: G, D7, G, D7, G. A red arrow points from the text above to the first 'G' chord.

G D7 G D7 G

G D7 G D7 G

Sleep Baby Sleep

German Folksong

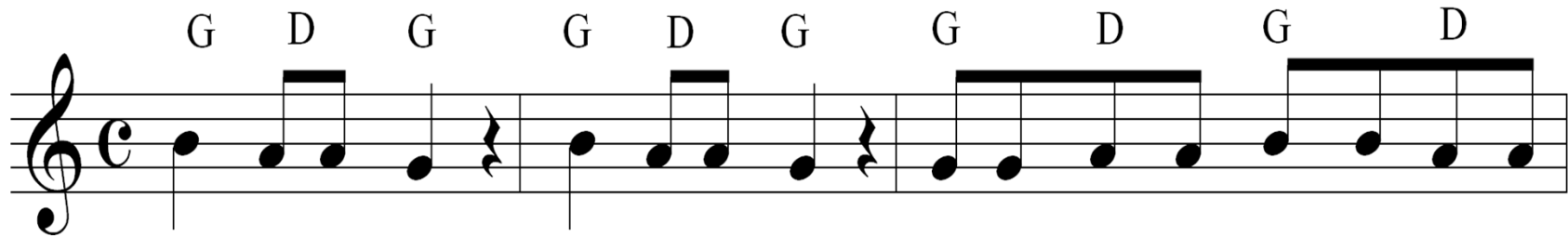

Sleep ba-by sleep, sleep ba-by sleep, Mo-ther shakes the dream-land tree and

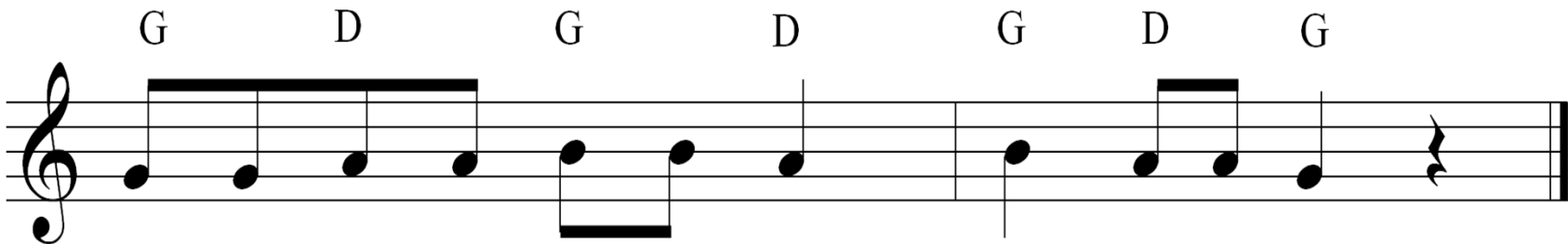

from it falls a dream for thee, sleep ba - by sleep.





Sleep Baby Sleep Extension

- Add a wind chime for an introduction and coda.
- Play a finger cymbal or triangle on all rests.
- Add a bass line.

BX

G D G D D G D G D D G D G D G

The image shows a musical staff for a bass line. The staff is in G major (one sharp) and common time (C). The notation consists of a sequence of notes: G4 (quarter), D4 (quarter), G4 (quarter), D4 (quarter), D4 (quarter), G4 (quarter), D4 (quarter), G4 (quarter), D4 (quarter), D4 (quarter), G4 (quarter), D4 (quarter), G4 (quarter), D4 (quarter), G4 (quarter). The notes are written on a five-line staff with a treble clef. Below the staff, the corresponding chord symbols are listed: G D G D D G D G D D G D G D G.

Syn-Co-Pa

Judah-Lauder

SR 1

SR 2

The first system of music is in 2/4 time with a key signature of one sharp (F#). It consists of two staves, SR 1 and SR 2. SR 1 has a treble clef and contains notes G4, A4, and B4 in the first measure, followed by rests in the second, third, and fourth measures. SR 2 has a treble clef and contains notes G3, A3, and B3 in the first measure, followed by rests in the second and third measures, and notes C4, D4, and E4 in the fourth measure. Chord symbols G, D, G, and D are placed above the first, second, third, and fourth measures respectively. The lyrics 'Syn - co - pa' are written below the first measure, and '1 2' are written below the second and third measures.

G D G D

Syn - co - pa 1 2

SR 1

SR 2

The second system of music continues in 2/4 time with a key signature of one sharp (F#). It consists of two staves, SR 1 and SR 2. SR 1 has a treble clef and contains notes G4, A4, and B4 in the first measure, notes G4, A4, and B4 in the second measure, notes C4, D4, and E4 in the third measure, and a whole note G4 in the fourth measure. SR 2 has a treble clef and contains notes G3, A3, and B3 in the first measure, notes G3, A3, and B3 in the second measure, notes C4, D4, and E4 in the third measure, and a whole note G3 in the fourth measure. Chord symbols G, G, D, and G are placed above the first, second, third, and fourth measures respectively. The lyrics 'syn - co - pa' are written below the first measure, 'sny - co - pa' below the second measure, and '1 2 3' below the third and fourth measures. The system ends with a double bar line and repeat dots.

G G D G

syn - co - pa sny - co - pa 1 2 3

syn - co - pa syn - co - pa 1 2 3

Grandma Grunts

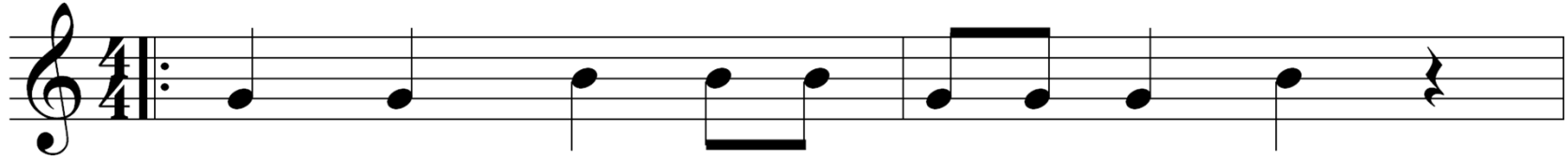

Grand - ma is Grunts said a cu - ri - ous thing.
That is all I heard her say.



Boys can whis - tle but girls must sing.
Heard her say it just yes - ter - day.

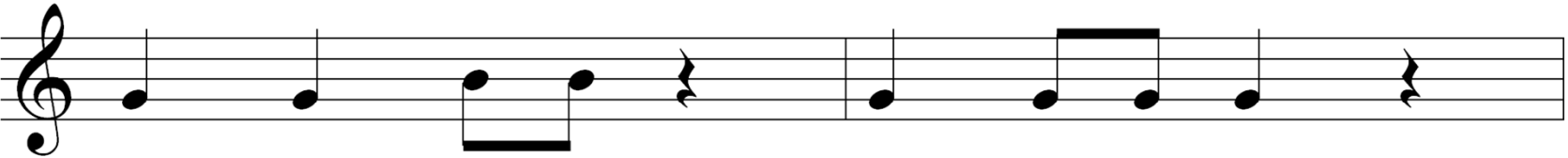

Boys can whis - tle (whistle)

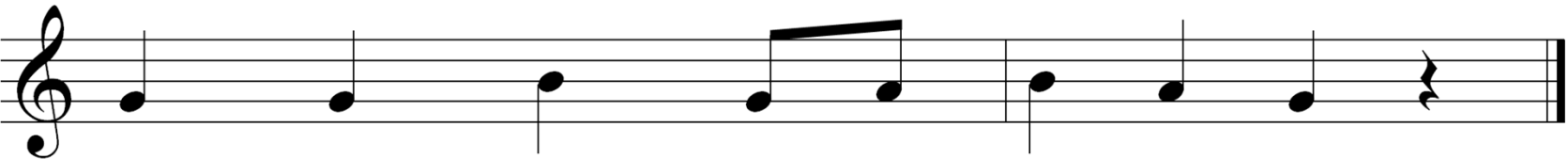

Girls must sing tra la la la la

Grandma Grunts Extension

Tamb

Drum

The image shows two staves of music. The top staff is labeled 'Tamb' and the bottom staff is labeled 'Drum'. Both are in 4/4 time. The Tamb staff has a sequence of notes: quarter, eighth, quarter, eighth, quarter, eighth, quarter, eighth. The Drum staff has a sequence of notes: quarter, eighth, quarter, eighth, quarter, eighth, quarter, eighth.

BX

G D' D' G D'

The image shows a single staff of music for 'BX' in G major (one sharp) and 4/4 time. The notes are G, D', D', G, D'. Below the staff, the notes are written as 'G D' D' G D'.

Grandma Grunts



Grand - ma is Grunts said a cu - ri - ous thing.
That ma is all I heard her say.



Boys can whis - tle but girls must sing.
Heard her say it just yes - ter - day.

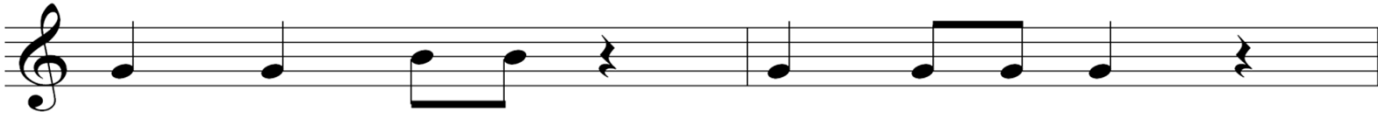

Boys can whis - tle (whistle)



Girls must sing tra la la la la

Tamb

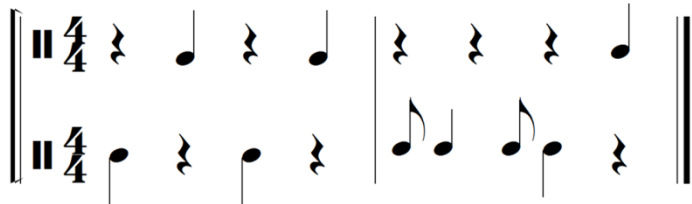

Drum

BX

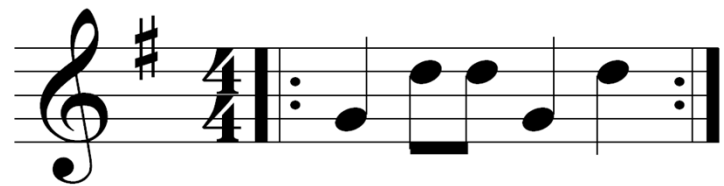



The Cricket

Judah-Lauder

SR 1

SR 2

G D

The noi - sy lit - tle crick - et chirp - ing all night long.

4/4

SR 1

SR 2

G

Lis - ten Lis - ten. The noi - sy lit - tle crick - et

Guero Guero

4/4

SR 1

SR 2

D G G D G

chirp - ing all night long. Lis - ten Chirp - ing all night long.

Guero

4/4



The Cricket Extension

BM
BX

The musical notation is written on a grand staff with two staves, BM (Bass) and BX (Bass). The key signature is one sharp (F#) and the time signature is 4/4. The melody consists of the following notes: G4 (quarter), D5 (quarter), D4 (half), D5 (quarter), D5 (quarter), G4 (quarter), D5 (quarter), G4 (quarter), D5 (quarter), D5 (quarter). The final D5 note is circled. A repeat sign is present at the beginning of the piece.

G D' D D' D' G D' G D' D'

D' Play high D

D Play low D